

MODEL NUMBER

TVL-AS2GNPM1A1

PRODUCT LINE

Switchbox TVF, TVH, and TVL

SPECIFICATIONS

Enclosure	Tropicalized Aluminum base and lid
Bus/Sensor	AS-Interface
Area Classification	Non-incendive
Visual Display	Standard 90° Green OPEN, Red CLOSED
Shaft	NAMUR
Conduit Entries	(2) 1/2" NPT
O-Rings	Silicone
Pilot	(1) 24Vdc pilot fail open/closed
Spool Valve	Aluminum Hard Coated anodized
Valve Cv	1.0 Cv (1/4" NPT Ports)
Manual Override	No manual override option
Regional Certification	No regional cert option
N Switch	No N Switch

WIRING DIAGRAM

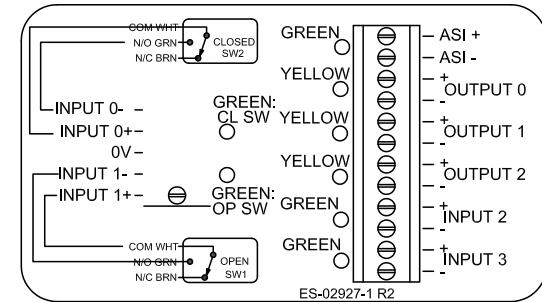

NAMEPLATE

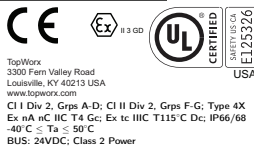

Telemetering Equipment for Hazardous Locations
WARNING: Substitution of components may impair suitability for use in Class I, Division 2 or Zone 2 environments. Must be known to be non-hazardous area before servicing. Enclosure contains aluminum - avoid ignition hazards due to impact or friction. Potential electrostatic charging hazard. Clean only with damp cloth.
AVERTISSEMENT: La substitution de composants peut nuire à l'utilisation en Classe I, Division 2 environnements. Doivent être connus pour être des zones non dangereuses avant l'entretien. Boîtier contient de l'aluminium - éviter inflammation due à des risques d'impact ou de friction. Danger potentiel de charge électrostatique - Nettoyer avec un chiffon humide.

Model #: _____ Serial #: _____

Current as of April 19, 2017 – Subject to change without notice.

TOPWORX

3300 Fern Valley Road
 Louisville, KY 40213

(502)969-8000 PH
 (502)969-5911 FAX
 www.topworx.com



Actuation Valve

www.actuation.co.uk
 tel: +44 (0)151 547 1221
 sales@actuation.co.uk